



**ESD300kV Test Systems for helicopters**

**System description**



<b>1.</b>	<b>ESD300KV TEST SYSTEM .....</b>	<b>2</b>
1.1	COVERED STANDARDS.....	2
1.2	TEST SETUP .....	2
<b>2.</b>	<b>SYSTEM COMPONENTS.....</b>	<b>3</b>
2.1	CHARGE CIRCUIT.....	5
2.2	DISCHARGE CIRCUIT .....	5
2.3	CONTROL UNIT.....	6
2.4	P-STATIC TEST SETUP .....	6
2.5	SYSTEM POWERING.....	7
2.6	SYSTEM MONITORING .....	7
<b>3.</b>	<b>SERVICES.....</b>	<b>7</b>
3.1	ONSITE INSTALLATION AND TRAINING .....	7
3.2	SYSTEM ACCEPTANCE .....	7
3.3	MAINTENANCE .....	7
<b>4.</b>	<b>SAFETY.....</b>	<b>7</b>
4.1	HIGH VOLTAGE.....	7
4.2	E/M RADIATIONS .....	7
<b>5.</b>	<b>MONTENA.....</b>	<b>8</b>
5.1	PRODUCTS.....	8
5.2	MIL STD SYSTEMS REFERENCES .....	9

Version 1.0 / 14.02.2012

S:\Prospectus\SystemDescriptionDocuments\ESD300kV\_System\_Description\_V10.doc

## 1. ESD300kV test system

### 1.1 Covered standards

Montena's test system is design to perform ESD tests up to 300kV according to :

- **MIL STD 331C**, Fuse and fuse components environmental and performance test: appendix F
- **MIL-STD-464A** (electromagnetic environmental effects requirements for systems).
- British Defence Standard **59-411 part 2** (electromagnetic compatibility / environment).
- **NATO AECTP-500** Electrostatic discharge, Munitions Test Procedure
- **NATO AECTP-501** General Guidance and Requirements
- **NATO AECTP-511** Electrostatic Discharge Method
- **STANAG 4235** (material for use by NATO forces), replaced by **AECTP 250 leaflet 253**.
- **STANAG 4239** (munitions), replaced by **AECTP 500 leaflet 508**.
- **STANAG 3516** For Aircraft Equipment
- **STANAG 4435, 4436, 4437** For Sea Equipment

### 1.2 Test setup

The test setup comprises following elements.

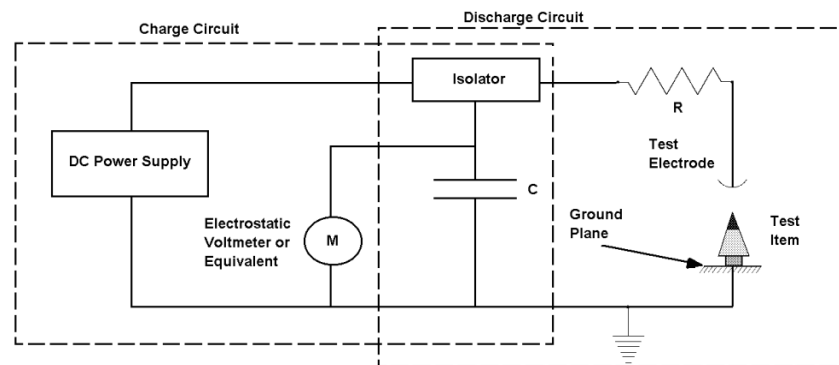

Figure 1 : schematic of a typical ESD 300kV test setup installation (from MIL STD-331)

The DC high voltage power supply charges the high voltage capacitor (C) up to a voltage of 300kV. This capacitor is then discharged by approaching the test electrode to the test item (EUT) which is connected to the ground.

A discharging resistor (R) optionally can be added in the discharge circuit. Some standards require a 500 ohm discharge resistor.

A high voltage divider voltmeter (M) can be included to ensure the capacitor's correct charging voltage.



## Pulse shapes

The pulse shape is not defined as such. The standard documents only define the maximal allowed induction of the discharge circuit as shown for example the table below, taken from MIL STD 331c.

**TABLE F1-I. Test parameters.**

Discharge Procedure	Voltage on C (kilovolts)	Capacitor C (picofarads)	Resistance R (ohms)	Discharge Inductance (microhenries)	Calibration Test Load (ohms)
Personnel	+25±5%	500±5%	5000±5%	< 5	1±5%
Personnel	-25±5%	500±5%	5000±5%	< 5	1±5%
Personnel	+25±5%	500±5%	500±5%	< 5	1±5%
Personnel	-25±5%	500±5%	500±5%	< 5	1±5%
Helicopter	+300±5%	1000±10%	1 max *	< 20	100±5%
Helicopter	-300±5%	1000±10%	1 max *	< 20	100±5%

\* Total distributed discharge circuit resistance.

## Clearing distances

The 300kV high voltage can generate electric arcs through the air if the distance between the charged elements and surrounding metallic structures is too short. A minimum distance of 2 meters should be considered to avoid such unexpected discharges.

## 2. System components

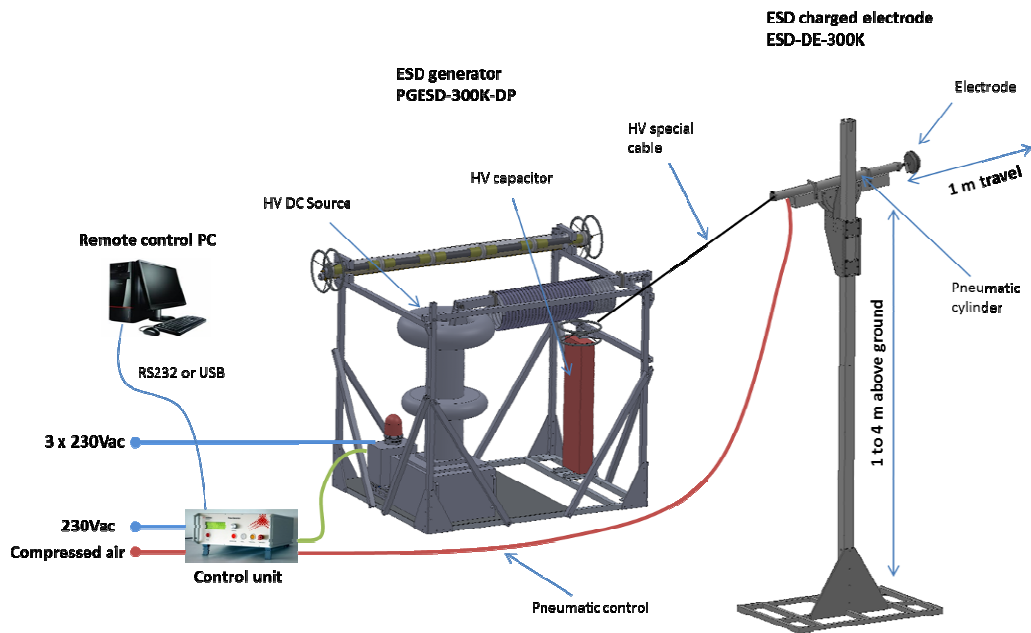

Figure 2 : Montena ESD 300kV test setup with 300kV charged electrode

The system from montena is built on two chassis. The first one with dimensions 2.25 x 1.50 x 1.85m (LxWxH) comprises the high voltage source, a charging resistor, the high voltage capacitor and the optional 500 ohms discharge resistor.

The second chassis with dimensions 2.0 x 1.0 x 4.0m (LxWxH) hosts the test electrode mounted on a pneumatic piston. This piston can be oriented in order to be able to approach the test electrode towards the desired contact point of the EUT. The pneumatic remote controlled piston allows a 1 meter travel distance of the test electrode



**montena**

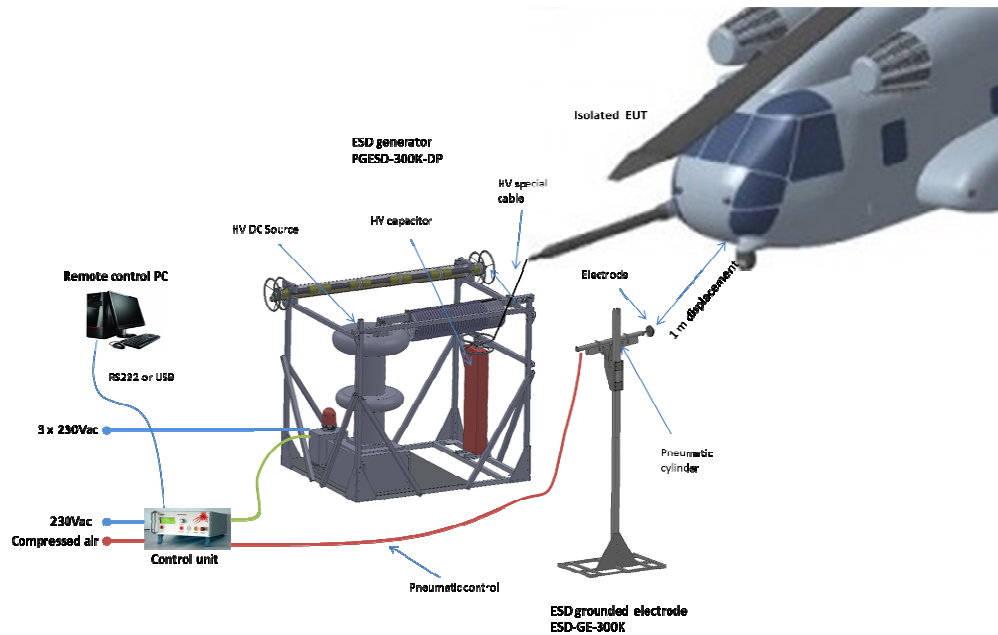

Figure 3 : Montena ESD 300kV test setup with grounded discharging electrode

In the above configuration the HV generator is directly connected to the EUT and charges it up to 300kV. The ESD electrode is connected to the ground and approached to the EUT to discharge it.

The figure below shows an example of ESD 300kV test setup developed by montena with a customized ESD electrode mast.

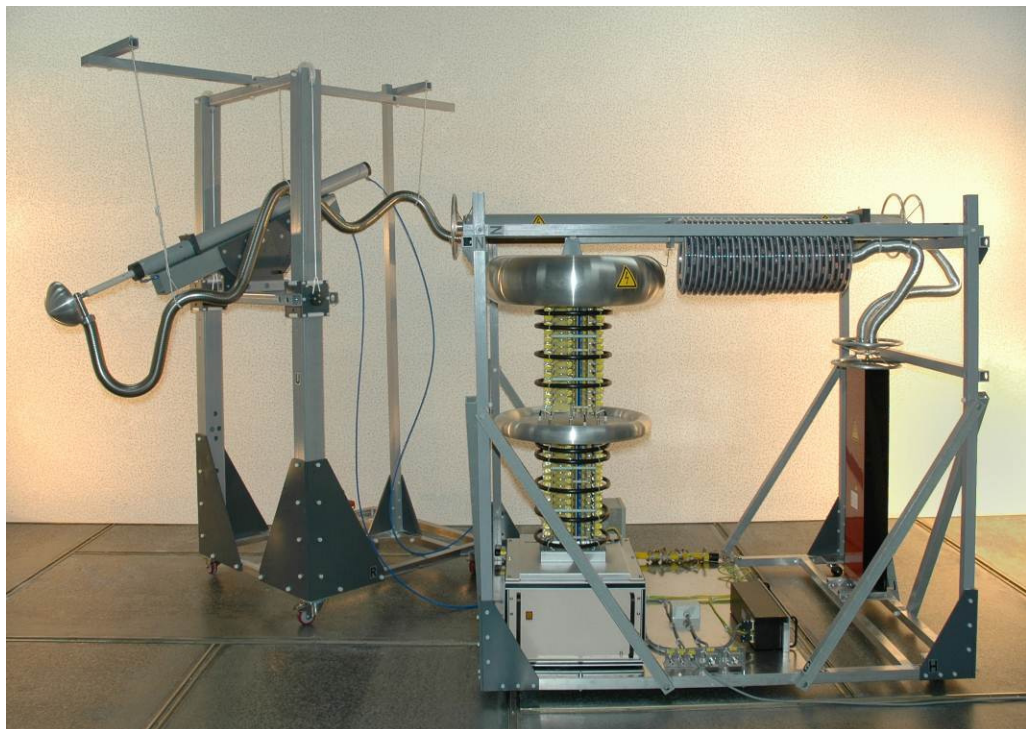

Figure 4 : Example of Montena ESD 300kV test setup



## 2.1 Charge circuit

The generator charges a 1 nF high voltage capacitor up to 300 kV with a constant current supply. Dual polarities are available. The capacitor and the High Voltage supply are separated by a 3 kOhm resistor chain. This resistor isolates the high voltage power supply during the discharge. The inductance of the resistor chain is about 3.5 mH. The figure below gives the simplified schematic of the generator.

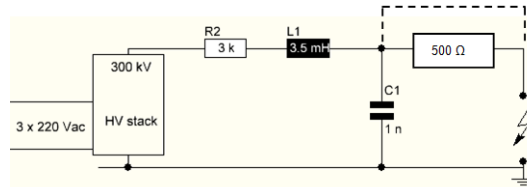

Figure 5 : schematic of the test installation

The 500 Ohm resistor can be inserted between the HV capacitor and the generator output.

For the test where the electrode is grounded and the insulated aircraft charged, the power of the generator needs to be compatible with the load (aircraft) and shall be dimensioned accordingly.

The DC source provides a voltage measurement indicating the source output voltage.

An optional voltage divider can be proposed on request to measure the charging voltage of the HV capacitor.

## 2.2 Discharge circuit

The high voltage capacitor is connected to an ESD discharge electrode which can be remotely moved by an air pressure controlled piston (1 meter travel, angle rotation of  $\pm 60$  degrees).

Once the capacitor is fully charged, the operator can move the ESD discharge electrode towards the EUT and once the ESD electrode is closed enough to the EUT an arc is formed between the electrode and the EUT. The current flows from the EUT back to the reference ground point of the system chassis.

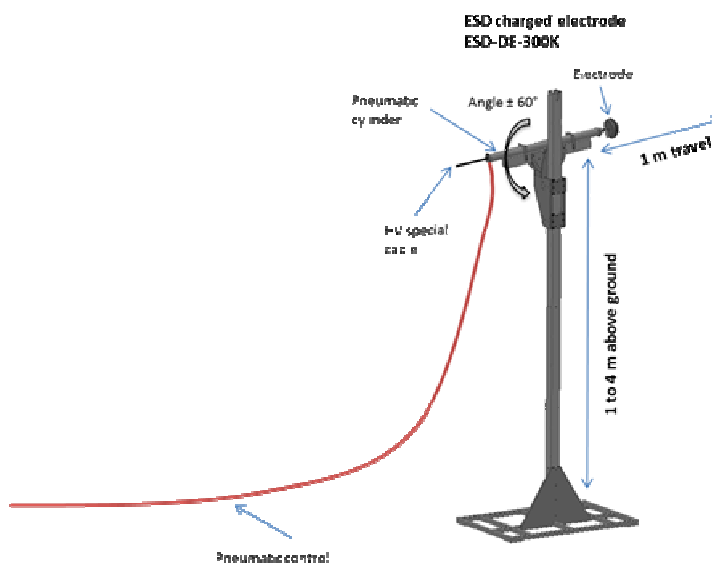

Figure 6 : ESD discharge electrode mechanism





## 2.3 Control unit

The remote control unit is connected to the HV generator and provide following features:

- Indication and setting of the HV charging voltage, adjustable voltage from 25 kV to 300 kV
- Interlock circuit allowing the connection of external safety features (as door switches)
- Remote control through RS232 interface

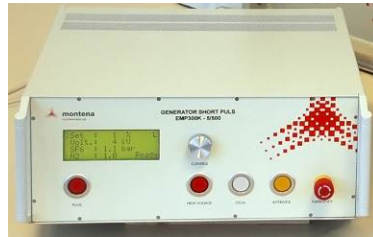

Figure 7 : Control unit

## 2.4 P-static test setup

The provided DC high voltage source can be used for P-static tests. Montena optionally provides the electrode for these precipitation tests.



Figure 8 : P-static system from Montena

The rod tips ionized the air and a current starts flowing through the air, charging the EUT as shown in the helicopter test example below. The precipitation test is performed at up to 100kV



Figure 9 : Example of P-static test



## 2.5 System powering

The system is powered 3 phases 230 V supply 4 kW (possible 110 V supply)

## 2.6 System monitoring

A current measurement device coupled on the discharged line is fitted in the test equipment. This current probe allows the monitoring of the discharge current and can be connected to an oscilloscope.

## 3. Services

### 3.1 Onsite installation and training

Montena provides onsite installation and training performed by either an engineer from montena or by a local authorized representative support engineer with help of skilled and unskilled workmen provided by the customer.

A training session is usually given directly after installation. This training includes the both the test system operation and maintenance.

### 3.2 System acceptance

The ESD300kV test setup acceptance procedure is performed with a verification of the generated ESD pulse based on:

- Charging voltage of the high voltage capacitor,
- Measurement of the discharge circuit's induction in a short circuit configuration

### 3.3 Maintenance

No periodical maintenance is required other than calibration of the measurement equipment.

On customer request montena can offer this calibration service with support of montena's authorized local representative.

## 4. Safety

### 4.1 High voltage

The control unit provides an input to connect safety equipment as door switches, etc.

Additionally the generator and the control unit have emergency security buttons. The high voltage capacitors will be automatically discharged through an internal resistor in case of power shut down.

### 4.2 E/M radiations

The ESD discharge generates an electromagnetic pulse in the vicinity of the test area. The operator should avoid having sensible electronic equipment too close from the test setup. Typical safe distance for electronic is about 10m.



## 5. Montena

Montena has been incorporated in 1903 as capacitor manufacturing company.

In 1978, montena emc was created to address the arising emc problems. Since then montena has earned a worldwide reputation for its leading-edge skills in the fields of high voltage, high frequency and electromagnetic fields.

Montena has the number one EMC test lab in Switzerland. With two large anechoic chambers, an open area test site and multiple shielded rooms, montena can test and validate all kinds of equipment.



Figure 10 : Montena emc headquarters - helicopter in an anechoic chamber

Montena can count on highly specialized know-how in the field of electromagnetic compatibility. These skills are put to good use in the development and construction of various kinds of equipment, especially emc test equipment and fast electrical pulse generator.

### 5.1 Products

Montena designs, builds and markets equipment and accessories for EMC tests. The range of products includes antennas, TEM cells, striplines, field sensors, all kind of pulse generators, test benches, etc.

Montena's high voltage pulse generators are mainly used for EMC tests, high speed imaging and pulsed light decontamination. Montena also builds pulse generators according the custom specific needs.



Figure 11 : some montena products





## 5.2 MIL STD Systems references

In the list below are some references of test systems according to MIL STD 461, MIL STD 188-125 and other military standard.



Marx pulse generator 320 kV, rise time 5 ns / duration 80 ns with control unit  
for NEMP test according to MIL STD 461 / RS105



NEMP test system according to MIL STD 461E - RS105 loading voltage 75 kV  
rise time 2.8 ns / duration 25 ns  
with 1.8 m high radiation line



NEMP test system according to MIL STD 461E - RS105  
Marx pulse generator 120 kV, rise time 2.8 ns / duration 25 ns  
with 2.7 m high radiation line



NEMP test system according to MIL STD 461E - RS105  
Marx pulse generator 230 kV, rise time 2.8 ns / duration 25 ns  
with 3.6 m high radiation line



NEMP test radiation for tests according to MIL STD 461E - RS105  
line 12 m high  
connected to an existing 600 kV pulse generator



NEMP test system according to MIL STD 461E - RS105  
Loading voltage 75 kV  
rise time 2.8 ns / duration 25 ns  
connected to a GTEM, 1m septum height



HV pulse generator 12kV, rise time 5 ns / duration 200 ns



High voltage pulse generator 80kV, rise time 5 ns / duration 500 ns  
for Pulse Current Injection test according to MIL STD 188/125, appendix B (short pulse)



Marx pulse generator 350 kV, rise time 5 ns / duration 500 ns with control unit  
for Pulse Current Injection according to MIL STD 188/125, short pulse



**montena**



Pulse generator 3 kV, rise time 0.6  $\mu$ s / duration 3.4 ms

for Pulse Current Injection according to MIL STD 188/125, intermediate pulse



Variable pulse length generator 25 kV, rise time < 5 ns / duration 3.4 ms

for Pulse Current Injection test according to MIL STD 188/125



Square pulse generator

for immunity test according to MIL STD 461 / CS115



Damped Sinusoidal pulse generator

for immunity test according to MIL STD 461 / CS116



HIRA antenna

Half impulse radiating antenna for the generation UWB E-field pulses (Ultra Wide Band pulses with sub nanosecond pulse duration)



ESD 300kV and P-static test system for helicopter and airborne systems