

E- and H-field Generator

S35012/1

10 kHz to 20 MHz

(optional 10 kHz to 30 MHz)

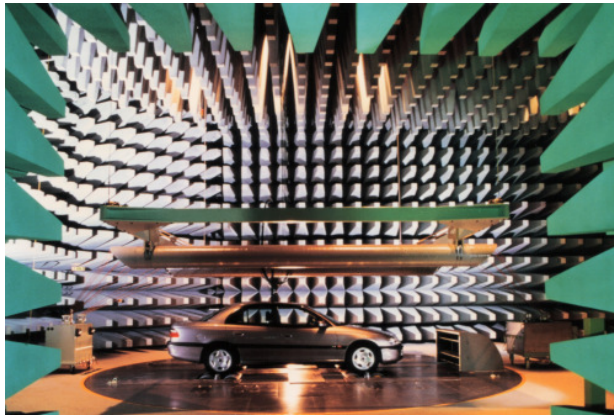

The E-/H-field generators series S35012/1 consist of two parallel conducting cylinders. Their distance and height above ground can be adjusted to the optimal geometry for testing. The network in the transformer unit either feeds the two conductors in phase or in push-pull mode. This enables one of the two conditions: The in-phase mode creates mainly vertical electrical field components between the conductors and the ground. The push-pull mode generates mainly horizontal electrical field components between the two conductors.

Because both modes have associated travelling waves along the conductors, with the resultant E- and H-fields, the radiation field of horizontally or vertically polarized antennas is simulated to a large degree. The different types of the E-/H-field generators differ in frequency range, maximum input power, the number of devices, which can be controlled remotely and in the mechanical dimensions.

1 Technical data

Electrical	Frequency range	10 kHz – 20 MHz (optional 10 kHz – 30MHz)
	Polarization	Vertical and horizontal
	Field strength with 10 kW	> 200 V/m (typ.)
	Input impedance	50 Ω
	VSWR	2 : 1 (typ.) 4 : 1 (max.)
	RF input power	2 / 10 / 15 kW (CW)
	RF connector	EIA 1 ⁵ / ₈ or 13-30 (with adapter)

1.1 Antenna Geometry

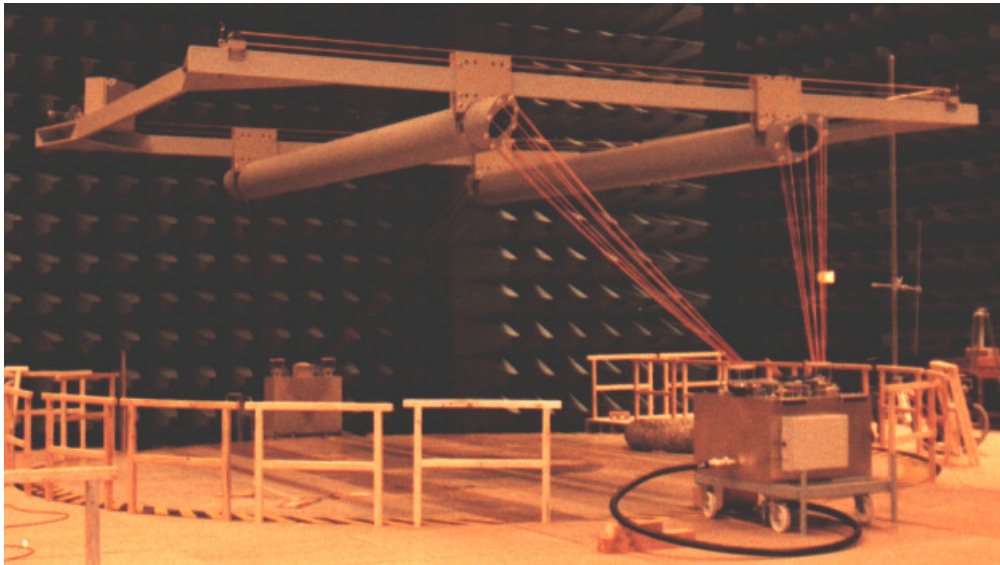

Figure 1: E-/H-field generator in an anechoic chamber

1.2 Measured Field Strength

The following graph shows the typical measured field strengths in push-pull mode (horizontally polarized) with 10 kW input power. The Sensor was situated in the middle of the measuring area at 1 m height above ground. The distance $2d$ of the conducting cylinders is 2 m, the height 2.5 m for curve 1 and 2.0 m for curve 2.

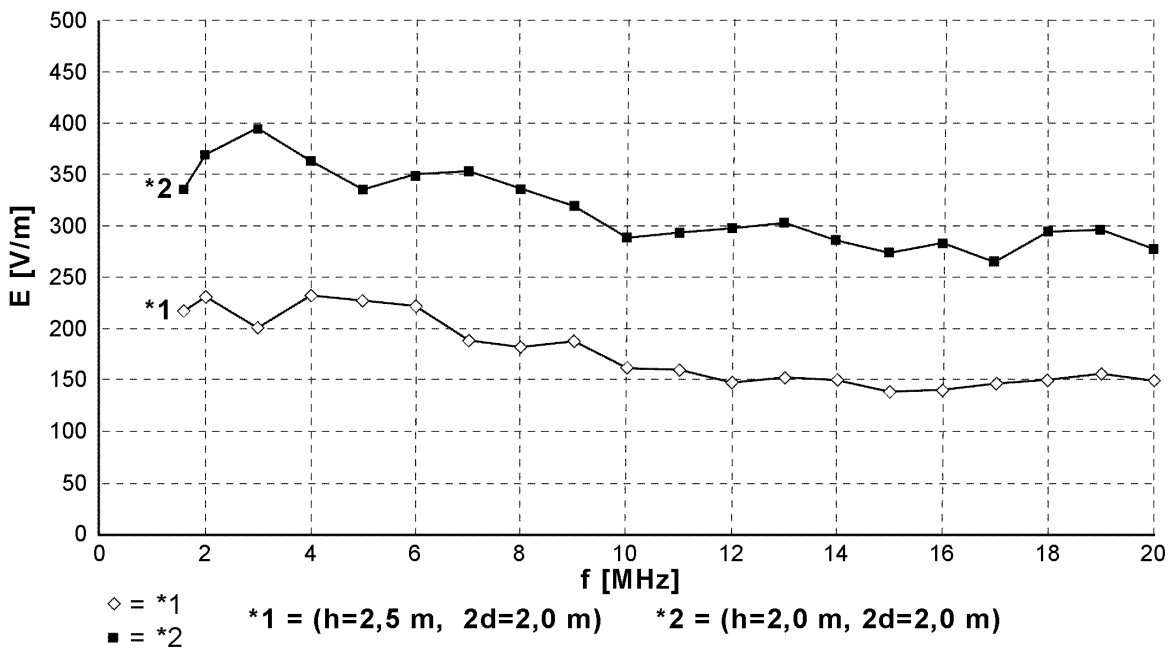

Figure 2: Measured field strengths at 10 kW with horizontal polarization

Typical measured field strengths for in-phase mode (vertically polarized) with 10 kW input power. The Sensor was situated in the middle of the measuring area at 1 m height above ground. 2d is the distance of the conducting cylinders and h means the height of the cylinders.

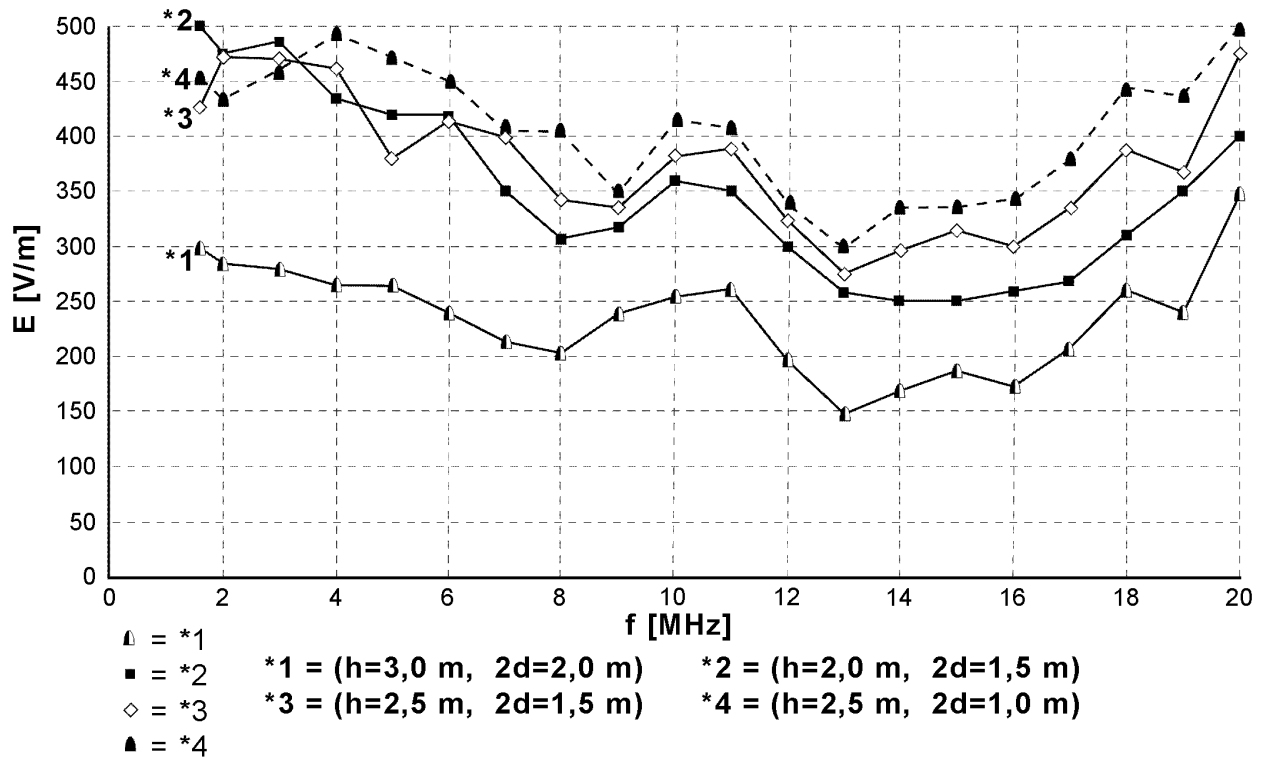

Figure 3: Measured field strengths at 10 kW with vertical polarizaion

2 System Components

The E-/H-field generator consists of the following components (see Fig. 4 and 5):

- Support structure with two conducting cylinders (1)
- Four sets of cage ropes, i.e. one for each end of the two conducting cylinders (2)
- Transformer unit (3)
- Termination unit (4)
- Ropes, pullies, winch form the suspension system (5) of the support structure (1)

2.1 Support Structure with two Conducting Cylinders

The two conducting cylinders form a pair of lines and are the field-generating part of the E-/H-field generator. The wooden support frame hangs from the ceiling by four ropes. The height of the cylinders over the ground plane can be adjusted by an electrical winch. Also the distance of the cylinders is adjustable. These adjustments are needed for matching the characteristic impedance of the two conducting cylinders. In the basic model the distance of the cylinders can be changed manually.

Length of Conducting Cylinders:	approx. 6.5 m
Dimensions of the Support Structure:	approx. 5.82 m x 7.32 m
Distance of Cylinders:	1.00 m – 4.52 m
Height of Cylinders:	1.5 m – 4.0 m

Possible Options:

Option 4.1: Motorized adjustment of cylinder distance

Option 4.2: Other mechanical dimensions and adjustment ranges are possible

2.2 Cage Lines

The cage lines connect the transformer unit (3) and the termination unit (4) to the conducting cylinders (1). They each consist of eight copper wires, which are kept in mechanical tension through a special construction in the cylinders. When the E-/H- generator is not in operation, the cage ropes can be disconnected from the transformer and termination unit. They retract almost completely into the cylinders.

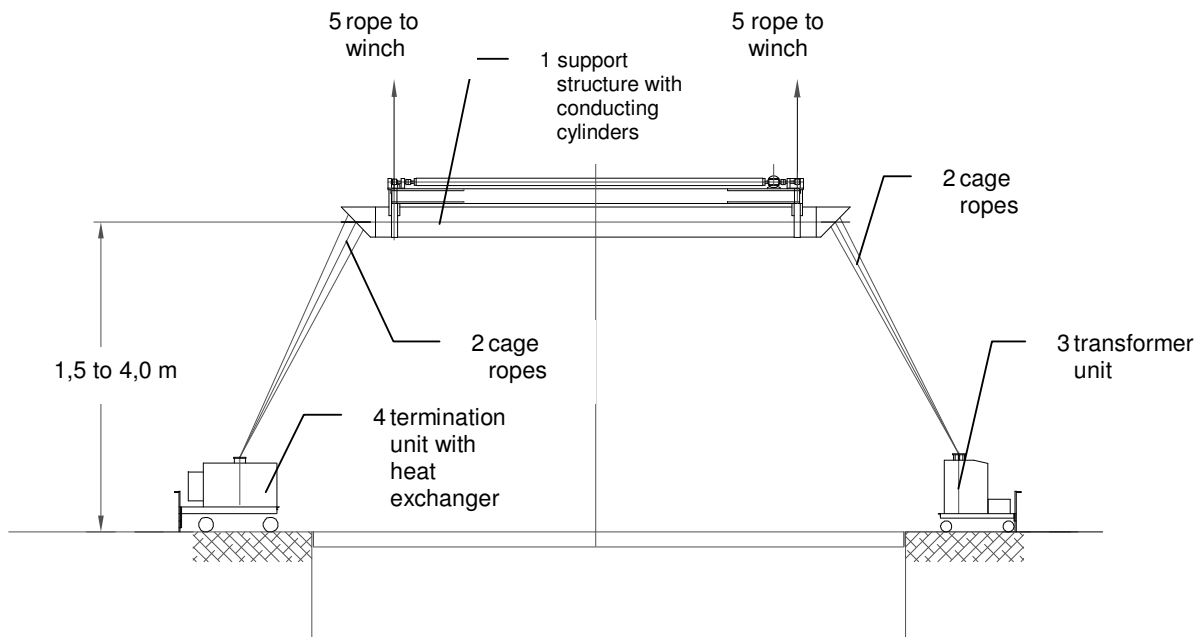

Figure 4: Side view of the E-/H-field generator

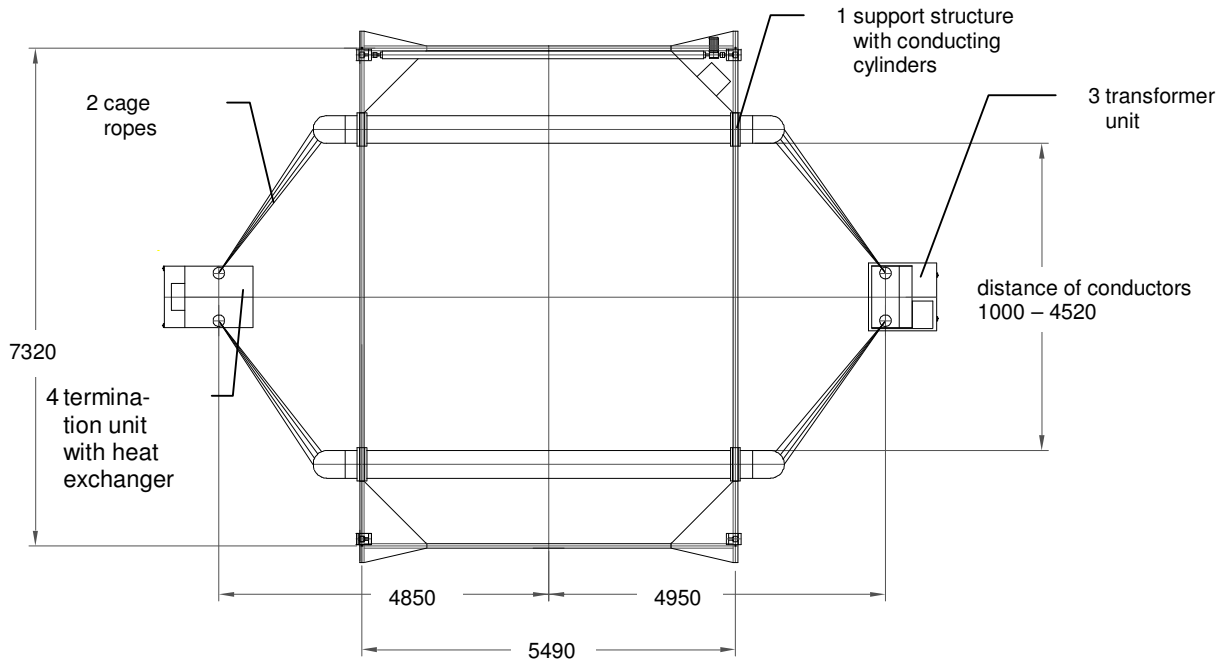

Figure 5: Top View of the E-/H-field generator

2.3 Transformer Unit

The transformer unit matches the impedance and symmetrizes the RF input power depending on the frequency range and on the operation mode (in-phase, push-pull) of the E-/H-field generator. Manual connection of the different contact points enable switching between the modes in the basic model. The transformer unit is installed on a dolly with wheels. Fast spanners guarantee a quick and safe connection of the cage lines to the transformer unit.

Frequency Range:	1.5 MHz – 20 MHz
Input Impedance:	50 Ω
Max. Input Power:	2 kW CW
RF-Connector:	EIA 1 5/8" 13-30 with adapter

System Interfaces

The RF-connector forms the RF interface to the customer. The housing of the transformer unit must be connected to the ground plane. Therefore six contact points must be installed in the ground plane of the chamber.

Options

- Option 4.3: Remote Control
- Option 4.4: Extended frequency range from 10 kHz
- Option 4.5: Higher input power up to 10 kW or 15 kW

2.4 Termination Unit

This unit terminates the double line with the correct impedance for both modes, which is accomplished without switching using a special circuit. In the basic version of the E-/H-field generator the termination has forced air-cooling. The FOC-connector provides a control signal for the temperature of the termination. The unit is installed on a dolly with wheels. Fast spanners guarantee a quick and safe connection of the cage lines to the transformer unit.

Frequency Range:	10 kHz – 20 MHz
Max. Input Power:	2 kW CW
Mains Connector:	Souriau 8.47.25F547N002 (shielded)
Mains Voltage and Current:	230 V / 50 Hz, ca. 4,2 A
FOC-connector:	1x FSMA

System Interfaces:

Line input and FOC connector form the interfaces to the cabling of the chamber.

The housing of the transformer unit must be connected with the ground plane. Therefore six contact points must be installed in the ground plane of the chamber.

Options:

Option 4.3: Remote Control

Option 4.5: Higher input power up to 10 kW or 15 kW

2.5 Ropes, Pullies and Winch

These components form the suspension of the support structure and the conducting cylinders. The winch can be controlled from the chamber per push button, enabling the setting of different heights for in-phase and push-pull mode. When not operating the generator, it can be moved up to the chamber ceiling. The uppermost position is secured by a switch. The non-conducting ropes pass through the chamber ceiling and pullies guide the ropes to the winch. For the mechanical safety concept we refer to our document B650 which can be sent upon request.

Mains Winch:	380/400V, 3 Phases 50 Hz, ca. 4 A continuous operation, approx. 30 A starting current
Dimensions Winch (L x B x H):	approx. 913 mm x 468 mm x 472 mm
Weight Winch:	approx. 300 kg
Mains Winch Controller:	230 V / 50 Hz, approx. 2 A
Rope Diameter:	8 mm
Section of suspension on support structure:	5490 mm (in axis) x 7320 mm

System Interfaces:

The weight of the E-/H-field generator including the additional tension of the cage lines places a mechanical load on the ceiling of approx. 640 kg, the winch weighs 300 kg. These are the static forces, the dynamic forces when advancing or stopping the generator are to be considered as well. The structural mechanics of the chamber ceiling must withstand these loads.

The feeds-through of the ropes through the chamber ceiling must be provided before installing the E-/H-field generator. Their position can differ slightly from the section on the support structure.

The winch mounting and the mains cables for winch and controller together with the controlling cable to the push button control in the chamber are not part of the scope of delivery.

For all the points mentioned above, FSA has detailed concepts and suggestions from a series of already delivered projects.

3 Options

3.1 Motorized adjustment of cylinder distance

A motor and a control box make a remote adjustment per push-button possible. The mains cable must be disconnected during HF power operation.

Mains Connector:	Souriau 8.47.25F547N002 (shielded)
Mains Voltage:	230 V 50 Hz

System Interface:

Line Input Connector

3.2 Other mechanical dimensions and adjustment ranges

Other mechanical dimensions and adjustment ranges are possible. Please contact FSA.

3.3 Remote Control of the Modes

With the remote control unit S42050/03 the different modes of the transformer unit can be switched from a distant location (e.g. control room). Vacuum switches are operated when the HF input power is switched off. Additional cables are needed for the transformer unit:

Mains Connector:	Souriau 8.47.25F547N002 (screened)
Mains Voltage:	230 V / 50 Hz, approx. 2.1 A
Connector for FOC:	2 x FSMA

* Mains cable and FOC are not part of the scope of delivery

Furthermore the temperature and (if needed) the coolant flow is monitored. When a critical value is exceeded the interlock contact will be opened and a SRQ on the IEEE Std 488.2-interface will be set. The FOC from the termination unit to the remote control unit is part of the chamber cabling. See also the data sheet of the remote control unit. The FOC connection of the termination unit is 2 x FSMA.

3.4 Higher Input Power up to 10 kW or 15 kW

This option influences the construction of the transformer and termination unit. A heat exchanger is added to the termination and connections for cooling water are provided.

Water Flow:	0,3 l/s i.e. 18 l/min
Water Input Temperature:	10°C max.
Water Output Temperature:	25°C max.
Mains Connector:	Souriau 8.47.25F547N002 (shielded)
Mains Voltage:	230V / 50 Hz, approx. 4.2 A
Connector for FOC:	1 x FSMA

3.5 50 Hz – E-/H-field generator

With this option 50 Hz - fields can be generated.

Mode E-Feld	4 kV/m
Mode H-Feld	140 dBpT

3.6 LEMP

Pulses of 4 kV/m with time constants of 1.2 resp. 50 μ s can be generated.

4 kV/m with time constants of 1.2 resp. 50 μ s can be generated.